

Installation Note

Extended Frequency Range Upgrade Kit

For E8362A PNA Series Microwave Network Analyzers WITH the Configurable Test Set Option

Network Analyzer Model Number	Upgrade Kit Part Number	Frequency Extension
E8362A, Option 014	E8362-60105	20 GHz to 40 GHz



Agilent Technologies

Agilent Part Number: E8362-90016

Printed in USA August 2004

© Agilent Technologies, Inc. 2004

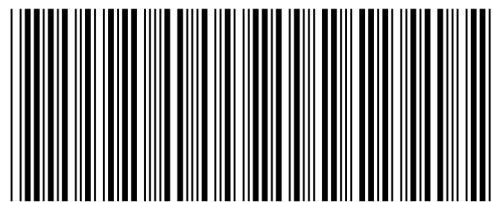

E8362- 90016

WARRANTY STATEMENT

THE MATERIAL CONTAINED IN THIS DOCUMENT IS PROVIDED “AS IS,” AND IS SUBJECT TO BEING CHANGED, WITHOUT NOTICE, IN FUTURE EDITIONS. FURTHER, TO THE MAXIMUM EXTENT PERMITTED BY APPLICABLE LAW, AGILENT DISCLAIMS ALL WARRANTIES, EITHER EXPRESS OR IMPLIED WITH REGARD TO THIS MANUAL AND ANY INFORMATION CONTAINED HEREIN, INCLUDING BUT NOT LIMITED TO THE IMPLIED WARRANTIES OF MERCHANTABILITY AND FITNESS FOR A PARTICULAR PURPOSE. AGILENT SHALL NOT BE LIABLE FOR ERRORS OR FOR INCIDENTAL OR CONSEQUENTIAL DAMAGES IN CONNECTION WITH THE FURNISHING, USE, OR PERFORMANCE OF THIS DOCUMENT OR ANY INFORMATION CONTAINED HEREIN. SHOULD AGILENT AND THE USER HAVE A SEPARATE WRITTEN AGREEMENT WITH WARRANTY TERMS COVERING THE MATERIAL IN THIS DOCUMENT THAT CONFLICT WITH THESE TERMS, THE WARRANTY TERMS IN THE SEPARATE AGREEMENT WILL CONTROL.

DFARS/Restricted Rights Notice

If software is for use in the performance of a U.S. Government prime contract or subcontract, Software is delivered and licensed as “Commercial computer software” as defined in DFAR 252.227-7014 (June 1995), or as a “commercial item” as defined in FAR 2.101(a) or as “Restricted computer software” as defined in FAR 52.227-19 (June 1987) or any equivalent agency regulation or contract clause. Use, duplication or disclosure of Software is subject to Agilent Technologies’ standard commercial license terms, and non-DOD Departments and Agencies of the U.S. Government will receive no greater than Restricted Rights as defined in FAR 52.227-19(c)(1-2) (June 1987). U.S. Government users will receive no greater than Limited Rights as defined in FAR 52.227-14 (June 1987) or DFAR 252.227-7015 (b)(2) (November 1995), as applicable in any technical data.

Safety Notes

The following safety notes are used throughout this document. Familiarize yourself with each of these notes and its meaning before performing any of the procedures in this document.

WARNING	Warning denotes a hazard. It calls attention to a procedure which, if not correctly performed or adhered to, could result in injury or loss of life. Do not proceed beyond a warning note until the indicated conditions are fully understood and met.
----------------	---

CAUTION	Caution denotes a hazard. It calls attention to a procedure that, if not correctly performed or adhered to, could result in damage to or destruction of the instrument. Do not proceed beyond a caution sign until the indicated conditions are fully understood and met.
----------------	---

Getting Assistance from Agilent

By internet, phone, or fax, get assistance with all your test and measurement needs.

Online assistance: www.agilent.com/find/assist			
Americas			
Brazil (tel) (+55) 11 3351 7012 (fax) (+55) 11 3351 7024	Canada (tel) 888 447 7378 (fax) 905 282 6495	Mexico (tel) 1 800 254 2440 (fax) 1 800 254 4222	United States (tel) 800 829 4444 (alt) (+1) 303 662 3998 (fax) 800 829 4433
Asia Pacific and Japan			
Australia (tel) 1 800 225 574 (fax) 1 800 681 776 (fax) 1 800 225 539	China (tel) 800 810 0508 (alt) 800 810 0510 (fax) 800 810 0507 (fax) 800 810 0362	Hong Kong (tel) 800 933 229 (fax) 800 900 701	India (tel) 1600 112 626 (fax) 1600 112 727 (fax) 1600 113 040
Japan (Bench) (tel) 0120 32 0119 (alt) (+81) 426 56 7799 (fax) 0120 01 2144	Japan (On-Site) (tel) 0120 802 363 (alt) (+81) 426 56 7498 (fax) (+81) 426 60 8953	Singapore (tel) 1 800 275 0880 (fax) (+65) 6755 1235 (fax) (+65) 6755 1214	South Korea (tel) 080 778 0011 (fax) 080 778 0013
Taiwan (tel) 0800 047 669 (fax) 0800 047 667 (fax) 886 3492 0779	Thailand (tel) 1 800 2758 5822 (alt) (+66) 2267 5913 (fax) 1 800 656 336	Malaysia (tel) 1800 880 399 (fax) 1800 801 054	
Europe			
Austria (tel) 0820 87 44 11* (fax) 0820 87 44 22	Belgium (tel) (+32) (0)2 404 9340 (alt) (+32) (0)2 404 9000 (fax) (+32) (0)2 404 9395	Denmark (tel) (+45) 7013 1515 (alt) (+45) 7013 7313 (fax) (+45) 7013 1555	Finland (tel) (+358) 10 855 2100 (fax) (+358) (0) 10 855 2923
France (tel) 0825 010 700* (alt) (+33) (0)1 6453 5623 (fax) 0825 010 701*	Germany (tel) 01805 24 6333* (alt) 01805 24 6330* (fax) 01805 24 6336*	Ireland (tel) (+353) (0)1 890 924 204 (alt) (+353) (0)1 890 924 206 (fax) (+353) (0)1 890 924 024	Israel (tel) (+972) 3 9288 500 (fax) (+972) 3 9288 501
Italy (tel) (+39) (0)2 9260 8484 (fax) (+39) (0)2 9544 1175	Luxemburg (tel) (+32) (0)2 404 9340 (alt) (+32) (0)2 404 9000 (fax) (+32) (0)2 404 9395	Netherlands (tel) (+31) (0)20 547 2111 (alt) (+31) (0)20 547 2000 (fax) (+31) (0)20 547 2190	Russia (tel) (+7) 095 797 3963 (alt) (+7) 095 797 3900 (fax) (+7) 095 797 3901
Spain (tel) (+34) 91 631 3300 (alt) (+34) 91 631 3000 (fax) (+34) 91 631 3301	Sweden (tel) 0200 88 22 55* (alt) (+46) (0)8 5064 8686 (fax) 020 120 2266*	Switzerland (French) (tel) 0800 80 5353 opt. 2* (alt) (+33) (0)1 6453 5623 (fax) (+41) (0)22 567 5313	Switzerland (German) (tel) 0800 80 5353 opt. 1* (alt) (+49) (0)7031 464 6333 (fax) (+41) (0)1 272 7373
Switzerland (Italian) (tel) 0800 80 5353 opt. 3* (alt) (+39) (0)2 9260 8484 (fax) (+41) (0)22 567 5314	United Kingdom (tel) (+44) (0)7004 666666 (alt) (+44) (0)7004 123123 (fax) (+44) (0)7004 444555		
(tel) = primary telephone number; (alt) = alternate telephone number; (fax) = FAX number; * = in country number			
			8/03/04

About the Upgrade Kit

Products affected.	E8362A with Option 014, Configurable Test Set
Installation to be performed by	Agilent service center or personnel qualified by Agilent
Estimated installation time	4 hours
Estimated adjustment time	1 hour
Estimated full instrument calibration time	4.5 hours

If you need assistance, refer to [“Getting Assistance from Agilent”](#) on page 3.

Description of the Upgrade

This upgrade kit is used to extend the frequency range of the:

- E8362A, Option 014 PNA microwave network analyzer from 20 GHz to 40 GHz

Items Included in the Upgrade Kit

Check the contents of your kit against the following list. If any item is missing or damaged, contact Agilent Technologies. Refer to [“Getting Assistance from Agilent” on page 3](#).

Table 1 Option 041 Upgrade Kit (E8362-60105) to Extend the E8362A to 40 GHz

Ref. Desig.	Description	Qty	Part Number
Parts for ALL analyzers with Option 014 (with or without any other options)			
N/A	Installation note (this document)	1	E8362-90016
N/A	License key certificate	1	5964-5136
N/A	Model number nameplate (for 40 GHz analyzer, E8363A)	1	E8363-80001
A21	SOMA 50	1	5087-7130
A23	Channel R1 detector	2	5087-7133
A24	Channel R2 detector		
A25	Test port 1 coupler	2	5087-7518
A26	Test port 2 coupler		
A27	Channel A first converter (mixer)	2	5087-7122
A30	Channel B first converter (mixer)		
N/A	Machine screw M3.0 x 18 (for attaching A23 and A24 detectors)	4	0515-0666
N/A	Machine screw M3.0 x 30 (for attaching SOMA 50)	4	0515-1349
N/A	Ribbon cable, A21 SOMA 50 to A16 test set motherboard	1	8121-0818
N/A	Cable, wrapped wire, detectors to A16 test set motherboard	2	E7340-60075
N/A	Test set deck front panel	1	E8364-00014
W1	A12 source 20 to A21 SOMA 50	1	E8364-20036
W2	A21 SOMA 50 to A22 switch/splitter	1	E8364-20034
W3	A22 switch/splitter to A23 channel R1 detector	1	E8364-20023
W4	A22 switch/splitter to A24 channel R2 detector	1	E8364-20024
W37	A23 channel R1 detector to A16 test set motherboard J204	1	E8364-60121
W38	A24 channel R2 detector to A16 test set motherboard J205	1	E8364-60122
W39	A21 SOMA 50 to A16 test set motherboard J206	1	E8364-60123
W65	A23 channel R1 detector to REFERENCE 1 SOURCE OUT	1	E8364-20047
W66	A24 channel R2 detector to REFERENCE 2 SOURCE OUT	1	E8364-20048
W67	A25 test port 1 coupler to PORT 1 CPLR ARM	1	E8364-20043
W68	A26 test port 2 coupler to PORT 2 CPLR ARM	1	E8364-20044
W69	PORT 1 RCVR A IN to A27 channel A mixer	1	E8364-20045
W72	PORT 2 RCVR B IN to A30 channel B mixer	1	E8364-20046
W60	Front-panel jumper	6	E8364-20059

Table 1 Option 041 Upgrade Kit (E8362-60105) to Extend the E8362A to 40 GHz

Ref. Desig.	Description	Qty	Part Number
Parts for analyzers with Option 014 ONLY			
W61	A22 switch splitter to PORT 1 SOURCE OUT	1	E8364-20081
W62	A22 switch splitter to PORT 2 SOURCE OUT	1	E8364-20082
W63	PORT 1 CPLR THRU to A25 test port 1 coupler	1	E8364-20073
W64	PORT 2 CPLR THRU to A26 test port 2 coupler	1	E8364-20074
W70	REFERENCE 1 RCVR R2 IN to A28 channel R1 mixer	1	E8364-20075
W71	REFERENCE 2 RCVR R2 IN to A29 channel R2 mixer	1	E8364-20076
Parts for analyzers with Options 014 AND UNL			
A38	Port 1 bias tee	2	5087-7233
A39	Port 2 bias tee		
W70	REFERENCE 1 RCVR R2 IN to A28 channel R1 mixer	1	E8364-20049
W71	REFERENCE 2 RCVR R2 IN to A29 channel R2 mixer	1	E8364-20050
W81	A36 port 1 step attenuator to PORT 1 SOURCE OUT	1	E8364-20053
W82	A37 port 2 step attenuator to PORT 2 SOURCE OUT	1	E8364-20054
W83	PORT 1 CPLR THRU to A38 port 1 bias tee	1	E8364-20039
W84	PORT 2 CPLR THRU to A39 port 2 bias tee	1	E8364-20040

Installation Procedure for the Upgrade Kit

The network analyzer must be in proper working condition prior to installing this option. Any necessary repairs must be made before proceeding with this installation.

WARNING **This installation requires the removal of the analyzer’s protective outer covers. The analyzer must be powered down and disconnected from the mains supply before performing this procedure.**

Electrostatic Discharge Protection

Protection against electrostatic discharge (ESD) is essential while removing or connecting cables or assemblies within the network analyzer.

Static electricity can build up on your body and can easily damage sensitive internal circuit elements when discharged. Static discharges too small to be felt can cause permanent damage. To prevent damage to the instrument:

- *always* wear a grounded wrist strap having a 1 M Ω resistor in series with it when handling components and assemblies.
- *always* use a grounded, conductive table mat while working on the instrument.
- *always* wear a heel strap when working in an area with a conductive floor. If you are uncertain about the conductivity of your floor, wear a heel strap.

Figure 1 shows a typical ESD protection setup using a grounded mat and wrist strap. Refer to “Tools Required for the Installation” on page 8 for part numbers.

Figure 1 **ESD Protection Setup**

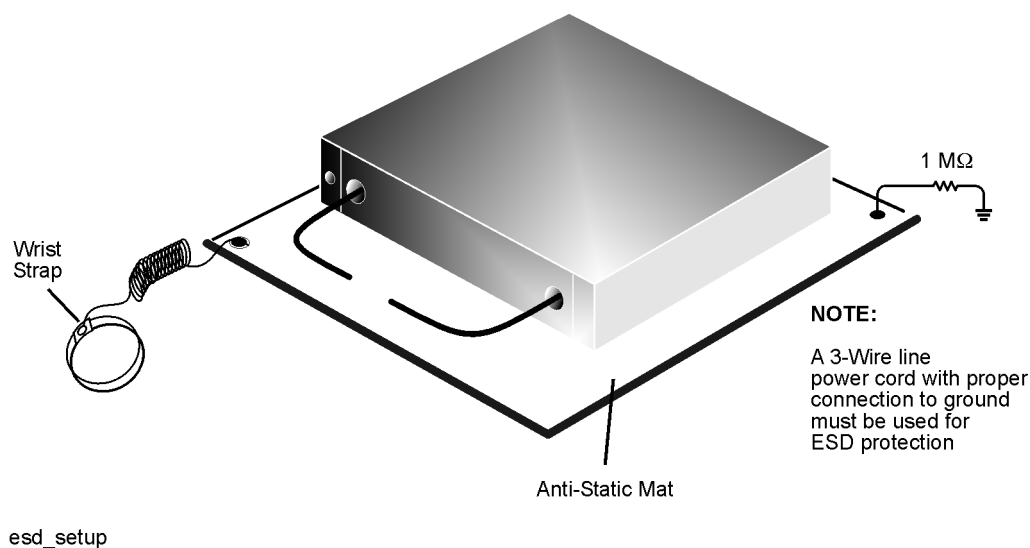

Overview of the Installation Procedure

- Step 1. Verify the Model, Serial, and Option Numbers of the Analyzer
- Step 2. Remove the Outer Cover
- Step 3. Remove the Inner Cover
- Step 4. Remove the Front Panel Assembly
- Step 5. Disconnect the A12 Source 20 to A22 Switch/Splitter Cable at the A12 Source 20
- Step 6. Raise the Receiver Deck
- Step 7. Remove the Old Hardware and Cables
- Step 8. Replace the A38 and A39 Bias Tees (Option UNL Only)
- Step 9. Install the Remaining New Hardware
- Step 10. Install the Remaining Cables
- Step 11. Lower the Receiver Deck
- Step 12. Connect the A12 Source 20 to A21 SOMA 50 Cable at the A12 Source 20
- Step 13. Replace the Front Panel Nameplate
- Step 14. Reinstall the Front Panel Assembly and Front Panel Jumpers
- Step 15. Reinstall the Inner and Outer Covers
- Step 16. Enter the New Model Number
- Step 17. Perform Source and Receiver Calibration Adjustments

Tools Required for the Installation

Description	Agilent Part Number
T-8 TORX driver (set to 5 in-lbs)	N/A
T-10 TORX driver (set to 9 in-lbs)	N/A
T-20 TORX driver (set to 21 in-lbs)	N/A
5/16-inch torque wrench (set to 10 in-lbs) ^a	N/A
5/16-inch torque wrench (set to 21 in-lbs) ^a	N/A
1-inch torque wrench (set to 72 in-lbs)	N/A

- a. Use a 5/16-inch torque wrench set to 10 in-lbs for all cable connections except the hex nuts on the front-panel bulkhead connectors to which the front-panel jumpers attach. Use a 5/16-inch torque wrench set to 21 in-lbs for these.

ESD Equipment and Supplies Required for the Installation

Description	Agilent Part Number
ESD grounding wrist strap	9300-1367
5-ft grounding cord for wrist strap	9300-0980
2 x 4 ft conductive table mat and 15-ft grounding wire	9300-0797
ESD heel strap (for use with conductive floors)	9300-1308

Equipment Required for Post-Installation Adjustments

Equipment Type	Model or Part Number	Alternate Model or Part Number
Power meter	E4418B/E4419B	E4418A/E4419A
Power sensor, 2.4 mm	8487A	None
Adapter, 2.4 mm (f) to 2.4 mm (f)	11900B	85056-60007
RF cable, 2.4 mm (f) to 2.4 mm (f)	85133C	85133E

Step 1. Verify the Model, Serial, and Option Numbers of the Analyzer

Refer to the License Key Certificate supplied with the kit:

- Verify that the analyzer's model and serial numbers match those on the certificate.
- Verify that the option number on the certificate matches the option described by this installation note.

If the model, serial, or option number do not match the expected results, you will not be able to install the option. If this is the case, contact Agilent for assistance. Refer to [“Getting Assistance from Agilent”](#) on page 3.

Step 2. Remove the Outer Cover

CAUTION

This procedure is best performed with the analyzer resting on its front handles in the vertical position. *Do not place the analyzer on its front panel without the handles.* This will damage the front panel assemblies.

1. Disconnect the power cord (if it has not already been disconnected).
2. Using a T-20 TORX driver, remove the strap handles (item ④) by loosening the screws (item ⑤) on both ends until the handle is free of the analyzer.
3. Using a T-20 TORX driver, remove the four rear panel feet (item ①) by removing the center screws (item ②).
4. Slide the four bottom feet (item ③) off the cover.
5. Slide the cover off of the frame.

Figure 2 Outer Cover Removal

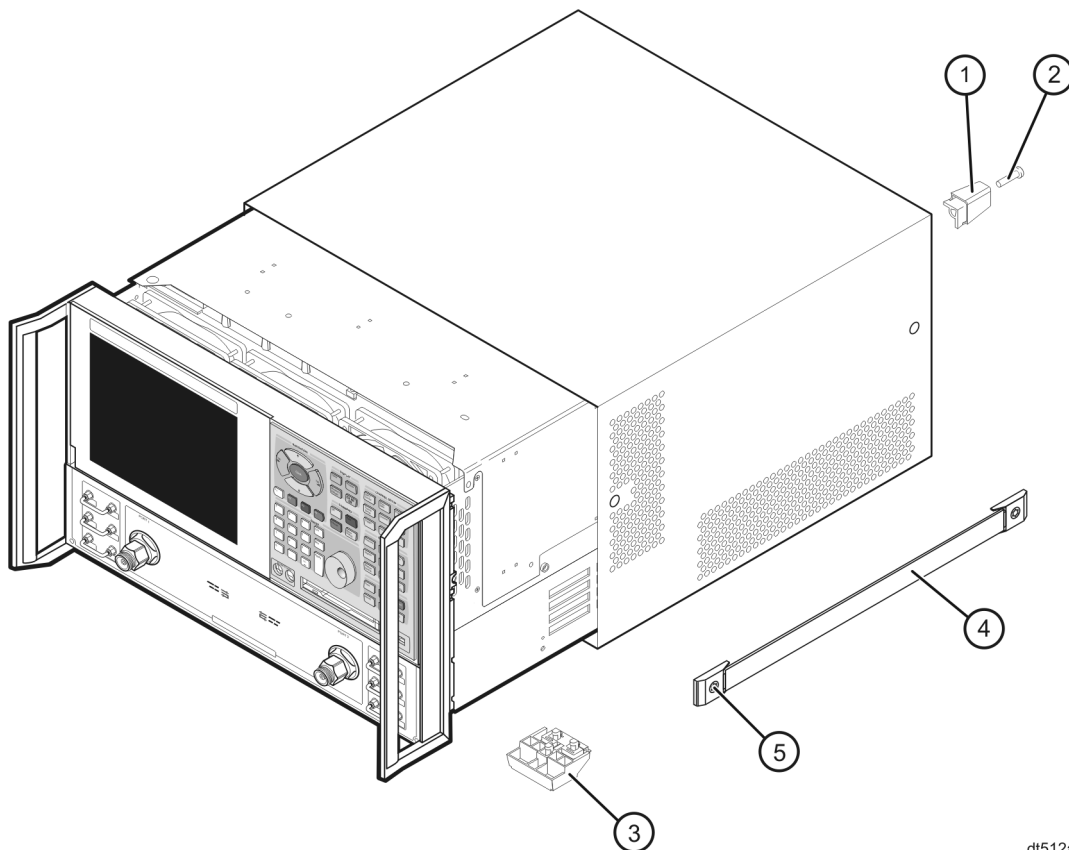

dt512a

Step 3. Remove the Inner Cover

1. Place the analyzer top-side up on a flat surface.
2. Using a T-10 TORX driver, remove the eleven screws (item ①).
3. Lift off the cover.

Figure 3 Inner Cover Removal

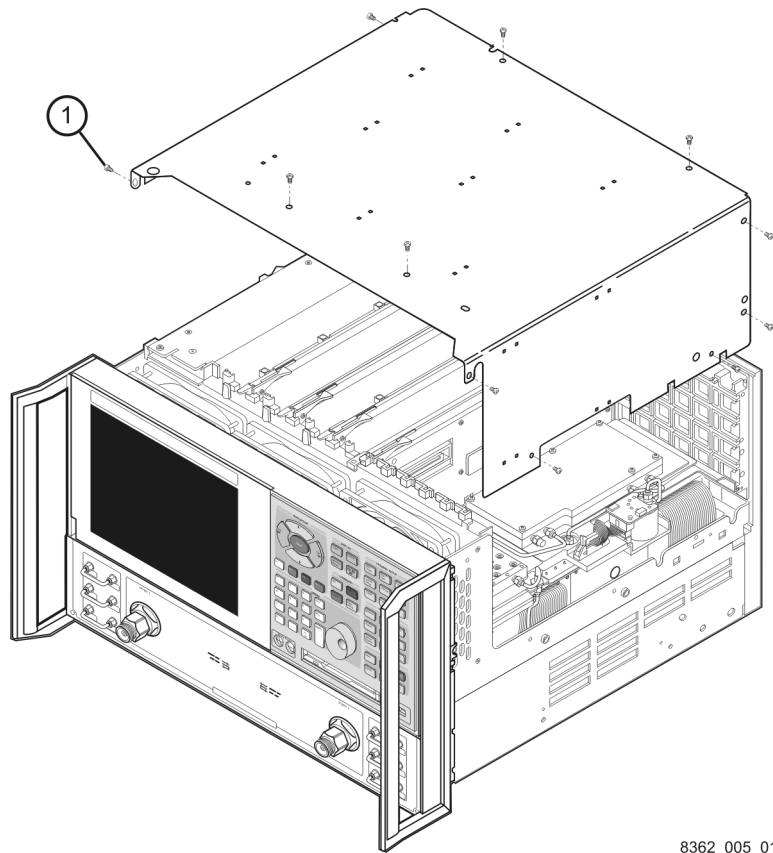

8362_005_01

Step 4. Remove the Front Panel Assembly

1. Using a 5/16-inch wrench, remove the six front panel semirigid jumper cables (item ①).
2. Using a T-10 TORX driver, remove the eight screws (item ②) from the sides of the frame.

CAUTION Before removing the front panel from the analyzer, lift and support the front of the analyzer chassis.

3. Slide the front panel over the test port connectors.
4. Disconnect the front panel interface ribbon cable (item ③). The front panel is now free from the analyzer.

Figure 4 Front Panel Assembly Removal

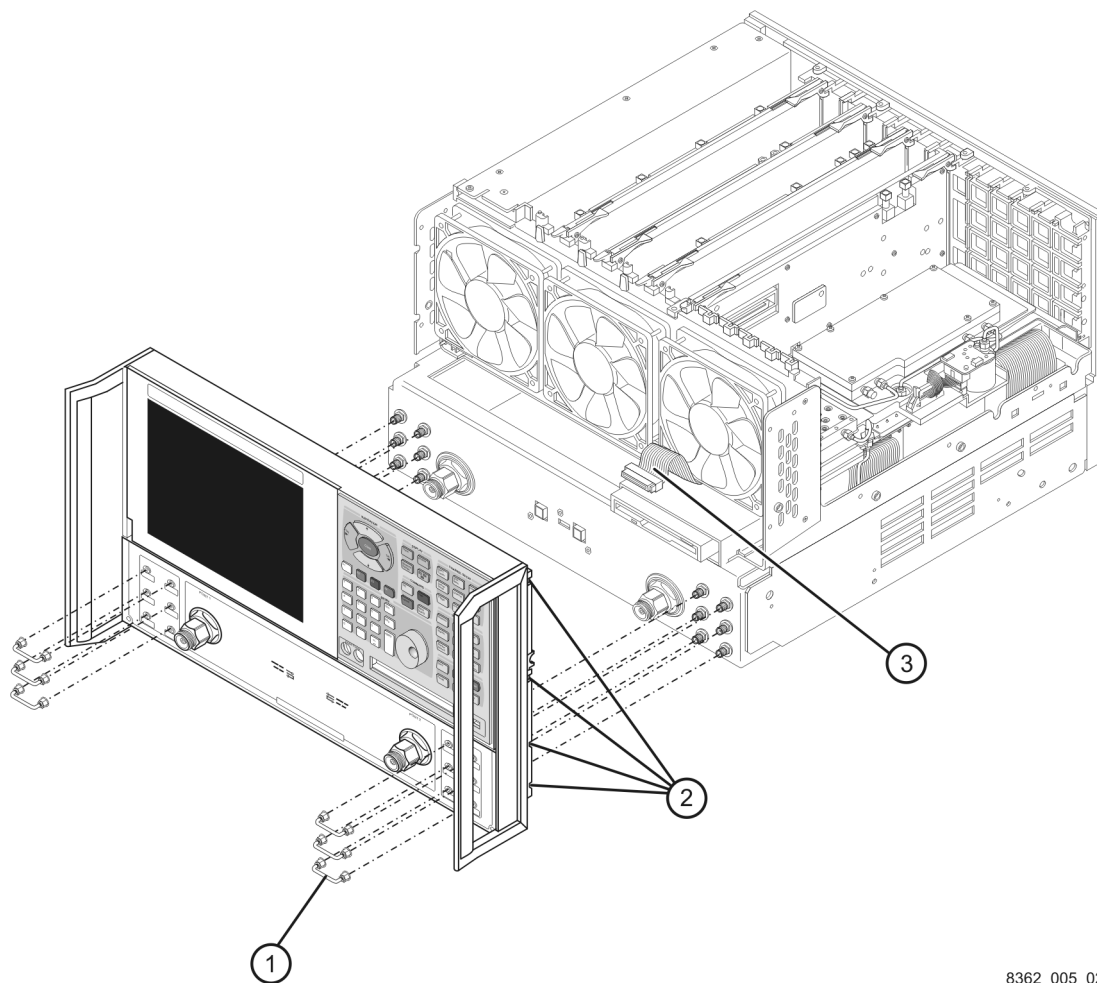

8362_005_02

Step 5. Disconnect the A12 Source 20 to A22 Switch/Splitter Cable at the A12 Source 20

1. Using a 5/16-inch wrench, disconnect the A12 source 20 to A22 switch/splitter cable, W1, at the A12 source 20 as shown.

Figure 5 A12 Source Cable Disconnection

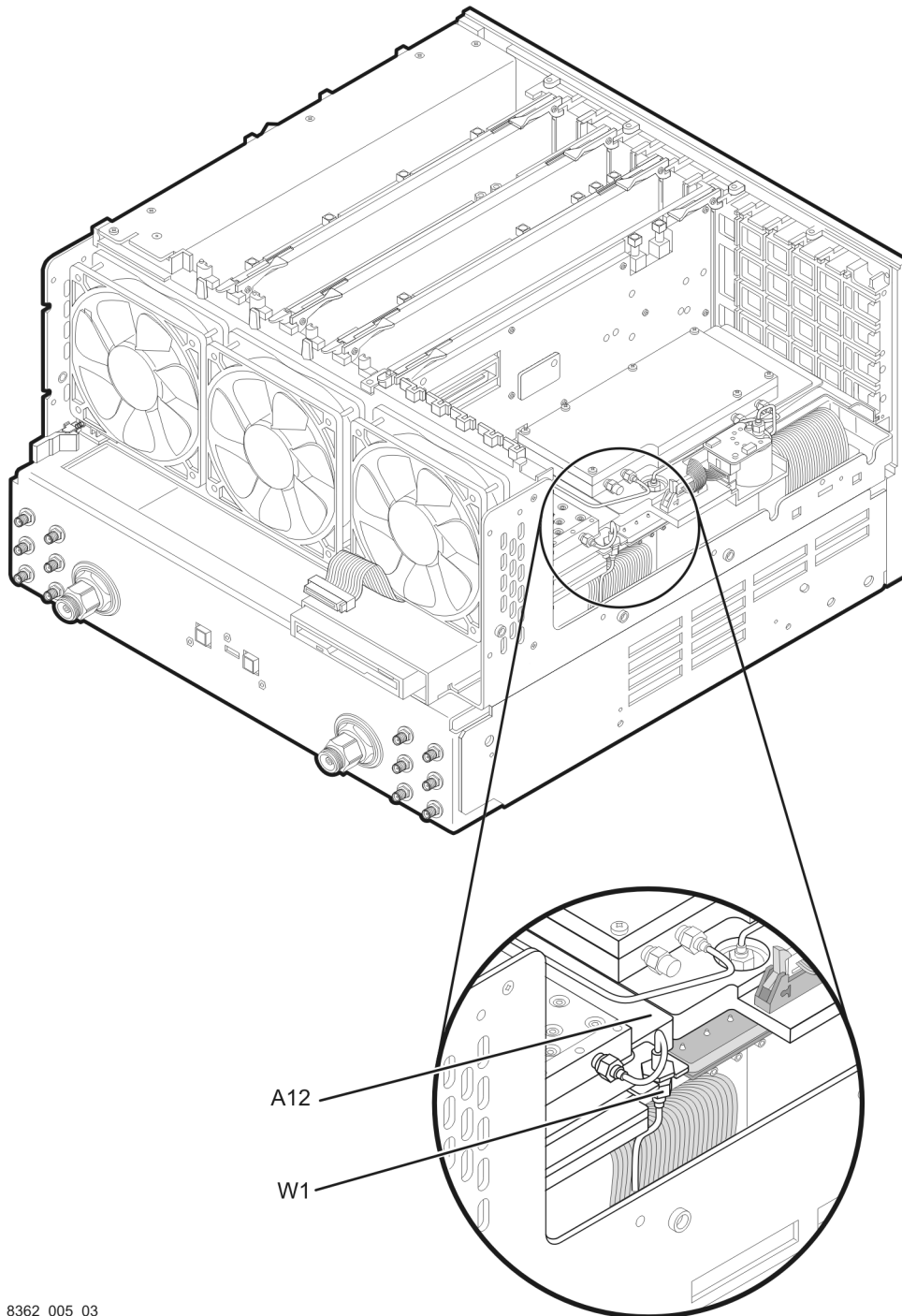

8362_005_03

Step 6. Raise the Receiver Deck

1. Place the analyzer bottom-side up on a flat surface.
2. Using a T-10 TORX driver, remove the four screws, (item ①), that secure the receiver deck.
3. Pull the latch pin (item ②) towards the opposite side of the analyzer to release the receiver deck.
4. Lift the receiver deck to partially raise it, then release the latch pin (item ②). Lift the receiver deck to its fully raised position and ensure that the latch pin latches in the raised position.

Figure 6 Receiver Deck Raising

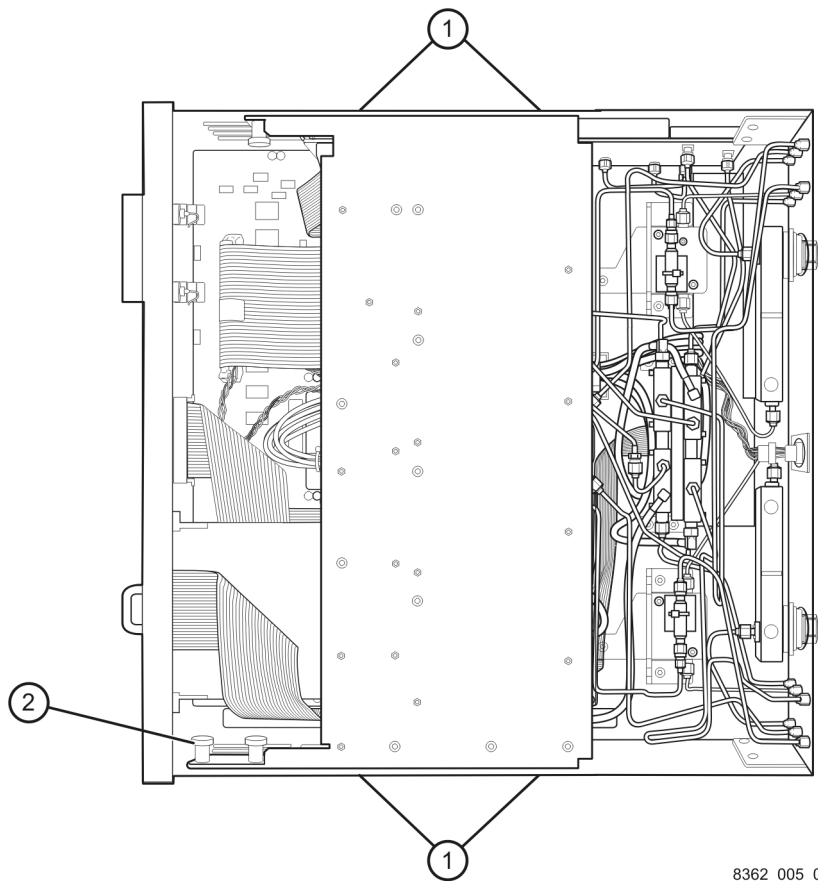

8362_005_04

Step 7. Remove the Old Hardware and Cables

Remove the Old Cables (Refer to [Figure 7.](#))

1. Using a 5/16-inch wrench, remove the following cables in the order listed.
 - W1 A12 source 20 to A22 switch splitter
 - W3 A22 switch splitter to channel R1 fixed attenuator
 - W4 A22 switch splitter to channel R2 fixed attenuator
2. Using a 5/16-inch wrench, remove the hex nuts from all 12 front panel connectors (item ①). Remove the lock washers.
3. Using a 5/16-inch wrench, remove each of the configurable test set cables (item ②) from the analyzer. Discard these cables, they will be replaced with new ones.

Remove the Fixed Attenuators (Refer to [Figure 7.](#))

4. Cut the cable ties (item ③).
5. Remove the attenuators (item ④) from the analyzer.
6. Remove the adhesive clamps (item ⑤) by sliding a thin, sharp blade under the clamp and lifting. Scrape away any excess adhesive from the bracket.

Replace the A27 and A30 Mixers (Refer to [Figure 7](#) and [Figure 8.](#))

7. Disconnect all RF cables (item ⑥) from the mixers.
8. Remove four screws (item ⑦) from the mixer bracket. Retain the screws for reinstallation later.
9. Remove the mixer bracket, with the mixers attached, from the analyzer. Observe the **CAUTION** below. Disconnect the ribbon cable to allow the mixer bracket to be removed.

CAUTION Be careful not to damage the center pins of the semirigid cables. Some flexing of the cables is necessary when removing the assemblies. Do not over-bend them.

10. Remove the old A27 and A30 mixers from the mixer bracket by removing three screws (item ⑧) from each, as shown in [Figure 8](#). Retain the screws to install the new mixers.
11. Install the new A27 and A30 mixers using the screws removed from the old mixers. Be sure to orient the mixers as shown in [Figure 8](#).
12. Reconnect the ribbon cable, and place the mixer bracket, with all four mixers attached, into the analyzer. Observe the **CAUTION** above.
13. Reinstall the four screws (item ⑦) to secure the bracket.
14. Reconnect all RF cables (item ⑥) to the mixers.

Figure 7 Old Hardware and Cables Removal

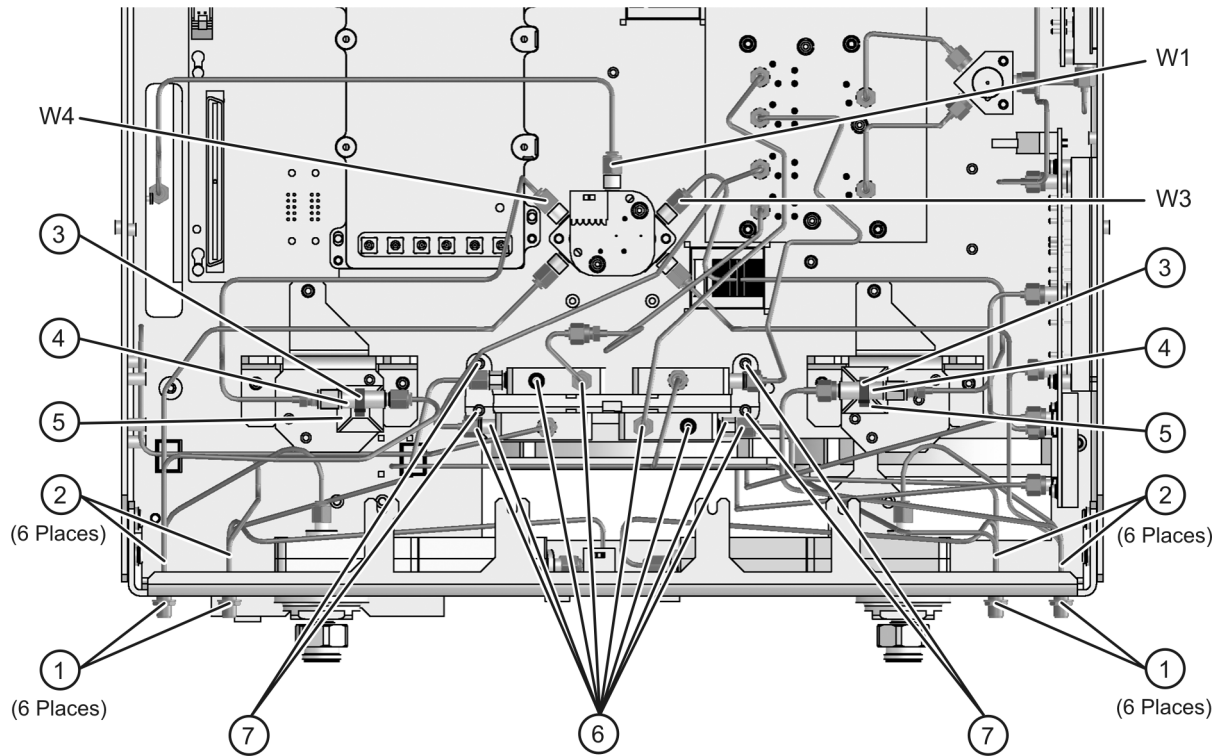

8362_005_05

Figure 8 Mixers Replacement

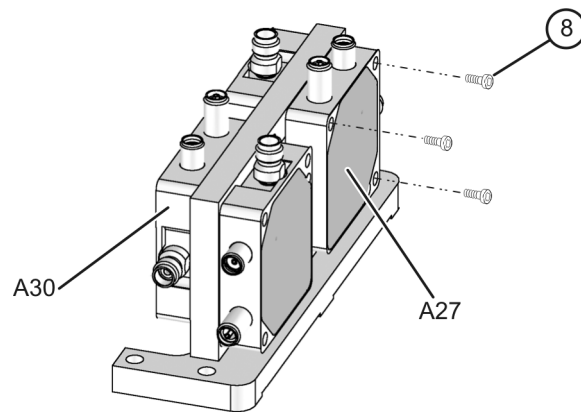

8362_005_06

Replace the Test Set Deck Front Panel and the A25 and A26 Test Port Couplers

Remove the Existing Test Set Deck Front Panel (Refer to [Figure 9](#).)

1. Disconnect the wrapped wire cable (item ①) from the front-panel LED board.
2. Disconnect any RF cables from the test port couplers that have not yet been removed.
3. Using a T-10 TORX driver, remove eight screws (items ① through ⑧) from the test set deck front panel, to release it.
4. Remove the test set deck front panel from the analyzer, with the LED board and both couplers attached.
5. Using a 1-inch wrench, remove the flange nut (item ②) from each coupler. Retain the flange nuts for installation of the new couplers.

Figure 9 Test Set Deck Front Panel Replacement

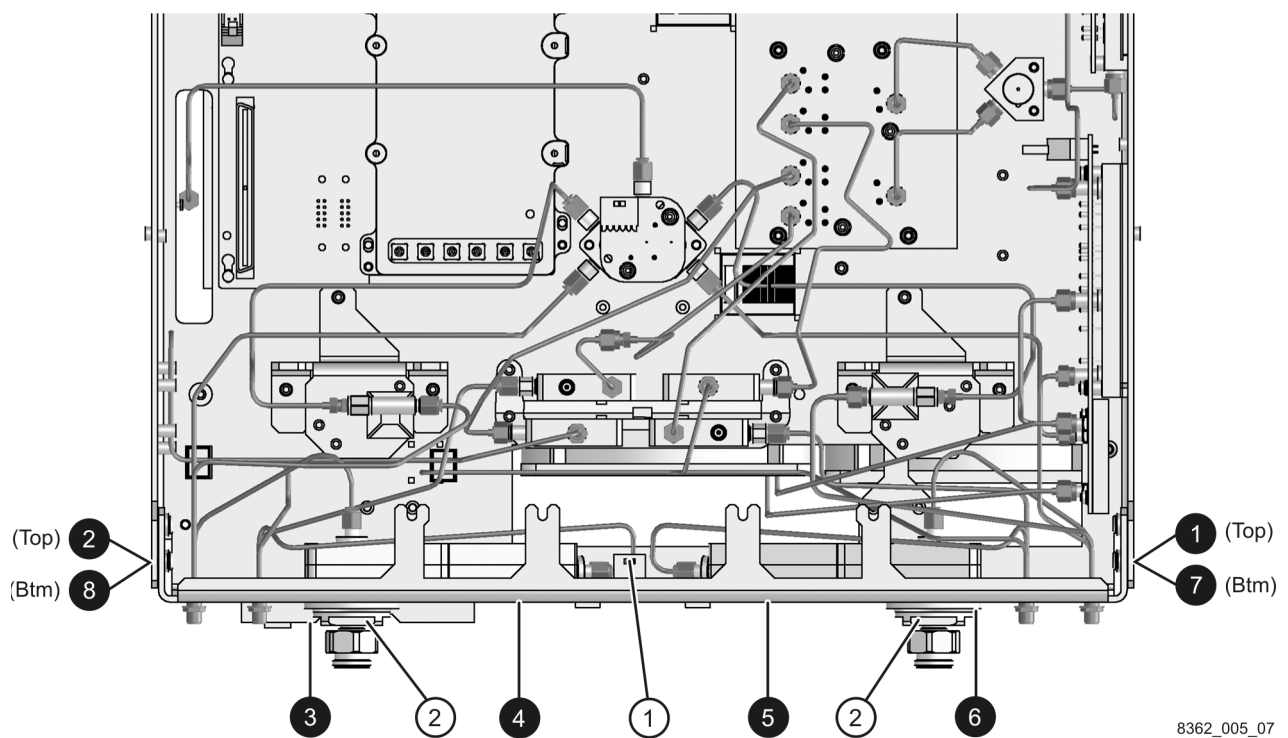

8362_005_07

Install the Old Front Panel LED Board onto the New Front Panel (Refer to [Figure 10.](#))

1. Remove the LED board from the old front panel by removing the three retaining screws (item ①).
2. Place the LED board in position on the new front panel and attach it with the three screws (item ①) removed from the old front panel.

Figure 10 Front Panel LED Board Reinstallation

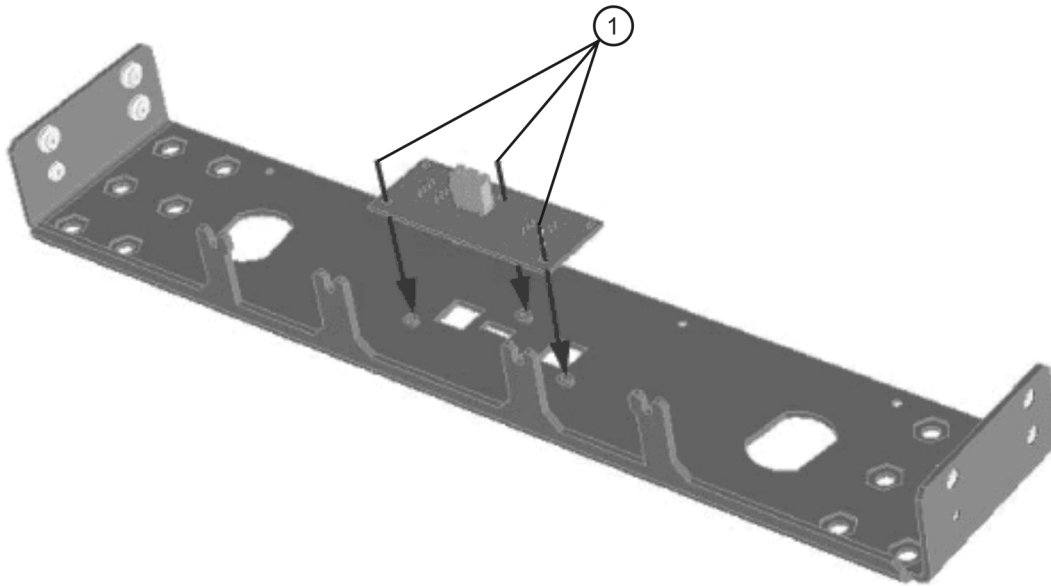

8362_005_08

Install the New Couplers on the New Front Panel (Refer to [Figure 9.](#))

1. Place the new couplers onto the new front panel. Orient them the same as the old ones as shown in [Figure 9.](#)
2. Install a flange nut (item ②) removed from the old couplers, onto each new coupler. Using a 1-inch torque wrench, tighten each flange nut to 72 in-lbs.

Install the New Test Set Deck Front Panel on the Analyzer (Refer to [Figure 9.](#))

1. Place the new test set deck front panel, with the new LED board and both new couplers attached, onto the test set deck as shown in [Figure 9.](#)
2. Using a T-10 TORX driver, *loosely* reinstall the eight screws (items ① through ⑧) to secure the front panel to the test set deck. Torque each of the eight screws to 9 in-lbs in the order indicated (① through ⑧). This is important to ensure proper alignment.
3. Reconnect the wrapped wire cable (item ①) to the front-panel LED board.

Replace the Bias Tees (Refer to [Figure 12](#).)

1. Remove the old bias tees from the bracket by removing two screws (item ①) from each. Retain the screws for installing the new bias tees.
2. Install the new bias tees using the screws (item ①) removed from the old bias tees. Be sure to install the ground lug (item ②) over the attachment screw as shown.

Figure 12 Bias Tees Replacement

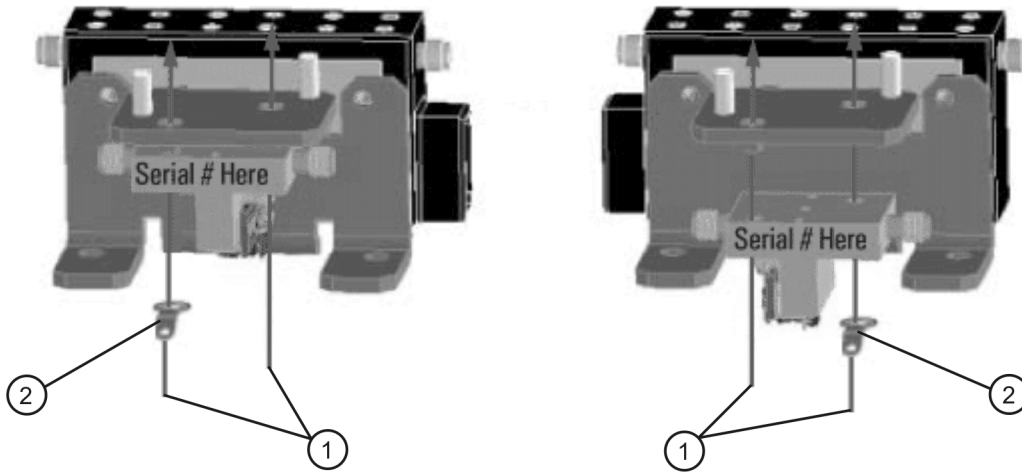

8362_005_10

Reinstall the Detector/Bias Tee/Attenuator Brackets (Refer to [Figure 11](#).)

1. Place the brackets, with the attenuators and bias tees attached, into the analyzer as shown in [Figure 11](#).
2. Reinstall the three screws (item ④) in each bracket.
3. Reconnect the ribbon cables to the attenuators (item ①).
4. Reconnect the bias tee control cables to the A16 test set motherboard. The A38 cable connects to J22 (P1 BIAS T) and the A39 cable connects to J25 (P2 BIAS T). Be sure to route them under the cable clamp, (item ③).
5. Reconnect the RF cables to the attenuators (item ①) and bias tees (item ②).

Step 9. Install the Remaining New Hardware

Install the A23 and A24 Detectors (Refer to [Figure 13](#).)

1. Place the A23 and A24 detectors on top of the brackets in the analyzer. Be sure to orient them as shown.
2. Install two screws (item ①) in each detector to secure them to the brackets.
3. Connect the wrapped wire control cables from the A23 and A24 detectors:
 - A23 detector to A16 test set motherboard J5 (R1 DET)
 - A24 detector to A16 test set motherboard J6 (R2 DET)

Install the A21 SOMA 50 (Refer to [Figure 13](#).)

1. Place the A21 SOMA 50 in position in the analyzer. Be sure to orient it as shown.
2. Install four screws (item ②) to secure the SOMA 50 to the A16 test set motherboard.
3. Connect the A21 SOMA 50 ribbon cable to A16 test set motherboard J4 (SOMA50).

Figure 13 A23 and A24 Detectors and A21 SOMA 50 Installation

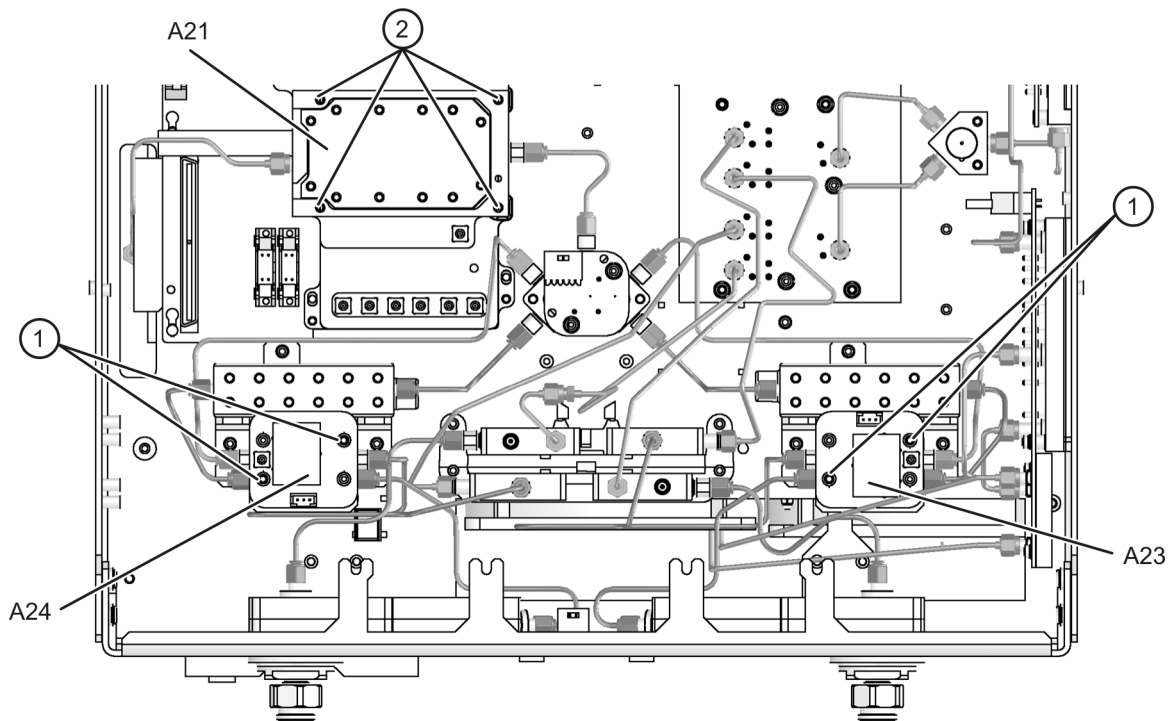

8362_005_11

Step 10. Install the Remaining Cables

Cables Common to All Analyzers with Option 014

Using a 5/16-inch torque wrench set to 10 in-lbs, install the following new cables **in the order listed**. Front panel connectors will be secured later. [Table 1 on page 5](#) lists the new parts.

- W1 A12 source 20 to A21 SOMA 50 (Connect this cable to the A21 SOMA 50 connector, as shown, with the other end of the cable routed through the opening to the top side of the analyzer. The other end of this cable will be connected later.)
- W2 A21 SOMA 50 to A22 switch/splitter
- W3 A22 switch/splitter to A23 channel R1 detector
- W4 A22 switch/splitter to A24 channel R2 detector
- W37 A23 channel R1 detector to A16 test set motherboard J204 (R1)
- W38 A24 channel R2 detector to A16 test set motherboard J205 (R2)
- W39 A21 SOMA 50 to A16 test set motherboard J206 (SOMA 50)

Figure 14 Cables Installation, Cables Common to All Analyzers

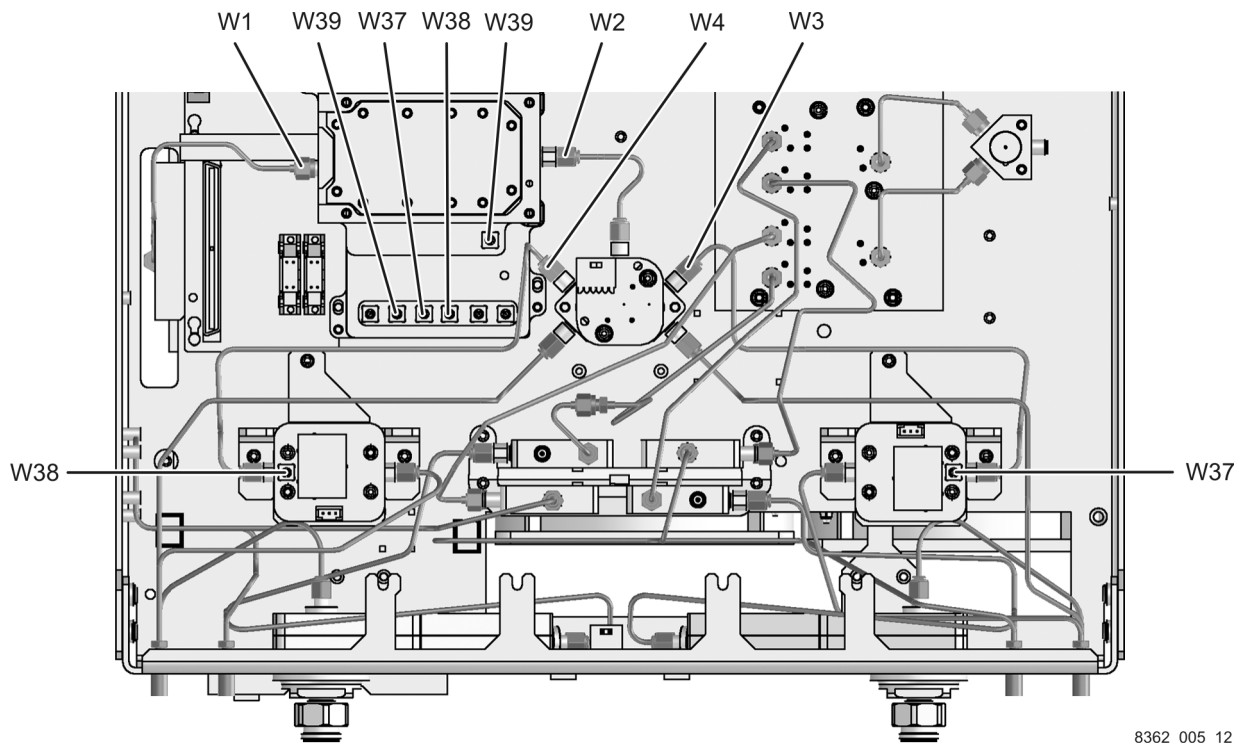

8362_005_12

Additional Cables for Analyzers with Only Option 014

Using a 5/16-inch torque wrench set to 10 in-lbs, install the following new cables **in the order listed**. Front panel connectors will be secured later. [Table 1 on page 5](#) lists the new parts.

- W61 A22 switch/splitter to PORT 1 SOURCE OUT
- W62 A22 switch/splitter to PORT 2 SOURCE OUT
- W63 PORT 1 CPLR THRU to A25 test port 1 coupler
- W64 PORT 2 CPLR THRU to A26 test port 2 coupler
- W65 A23 channel R1 detector to REFERENCE 1 SOURCE OUT
- W66 A24 channel R2 detector to REFERENCE 2 SOURCE OUT
- W67 A25 test port 1 coupler to PORT 1 CPLR ARM
- W68 A26 test port 2 coupler to PORT 2 CPLR ARM
- W69 PORT 1 RCVR A IN to A27 channel A mixer
- W70 REFERENCE 1 RCVR R1 IN to A28 channel R1 mixer
- W71 REFERENCE 2 RCVR R2 IN to A29 channel R2 mixer
- W72 PORT 2 RCVR B IN to A30 channel B mixer

Figure 15 Additional Cables Installation, Option 014 Only

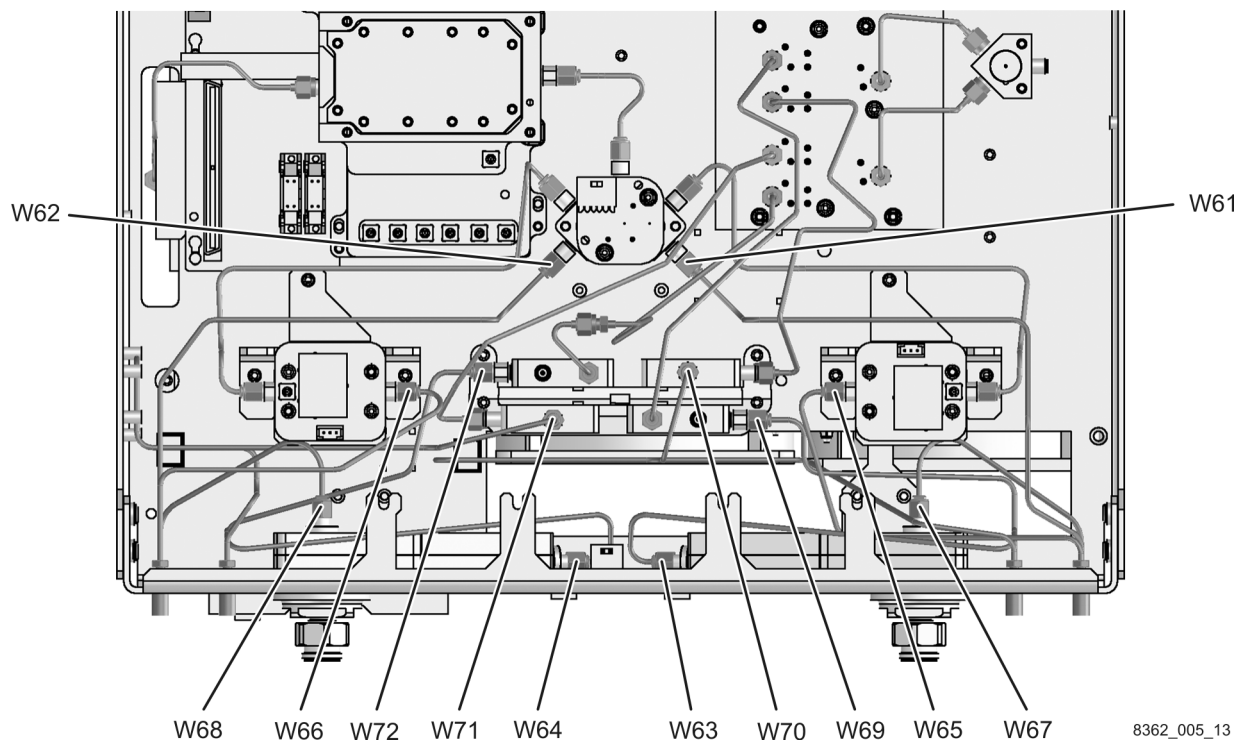

Additional Cables for Analyzers with Options 014 and UNL

Using a 5/16-inch torque wrench set to 10 in-lbs, install the following new cables **in the order listed**. Front panel connectors will be secured later. [Table 1 on page 5](#) lists the new parts.

- W65 A23 channel R1 detector to REFERENCE 1 SOURCE OUT
- W66 A24 channel R2 detector to REFERENCE 2 SOURCE OUT
- W67 A25 test port 1 coupler to PORT 1 CPLR ARM
- W68 A26 test port 2 coupler to PORT 2 CPLR ARM
- W69 PORT 1 RCVR A IN to A27 channel A mixer
- W70 REFERENCE 1 RCVR R1 IN to A28 channel R1 mixer
- W71 REFERENCE 2 RCVR R2 IN to A29 channel R2 mixer
- W72 PORT 2 RCVR B IN to A30 channel B mixer
- W81 A36 port 1 step attenuator to PORT 1 SOURCE OUT
- W82 A37 port 2 step attenuator to PORT 2 SOURCE OUT
- W83 PORT 1 CPLR THRU to A38 port 1 bias tee
- W84 PORT 2 CPLR THRU to A39 port 2 bias tee

Figure 16 Additional Cables Installation, Options 014 and UNL

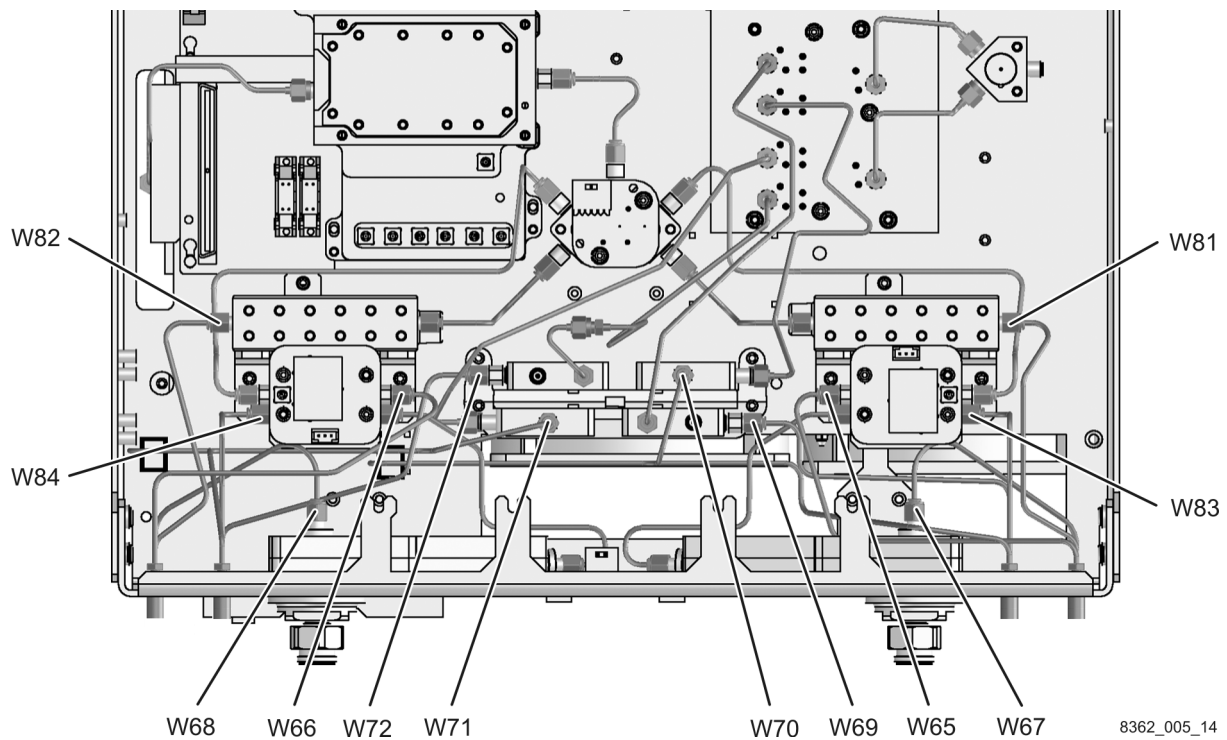

Step 11. Lower the Receiver Deck

1. Pull the latch pin (item ②) towards the opposite side of the analyzer to release the receiver deck.
2. Lift the receiver deck to partially lower it, then release the latch pin (item ②). Lower the receiver deck to its fully lowered position and ensure that the latch pin latches in the lowered position.
3. Using a T-10 TORX driver, reinstall the four screws, (item ①), to secure the receiver deck.

Figure 17 Receiver Deck Lowering

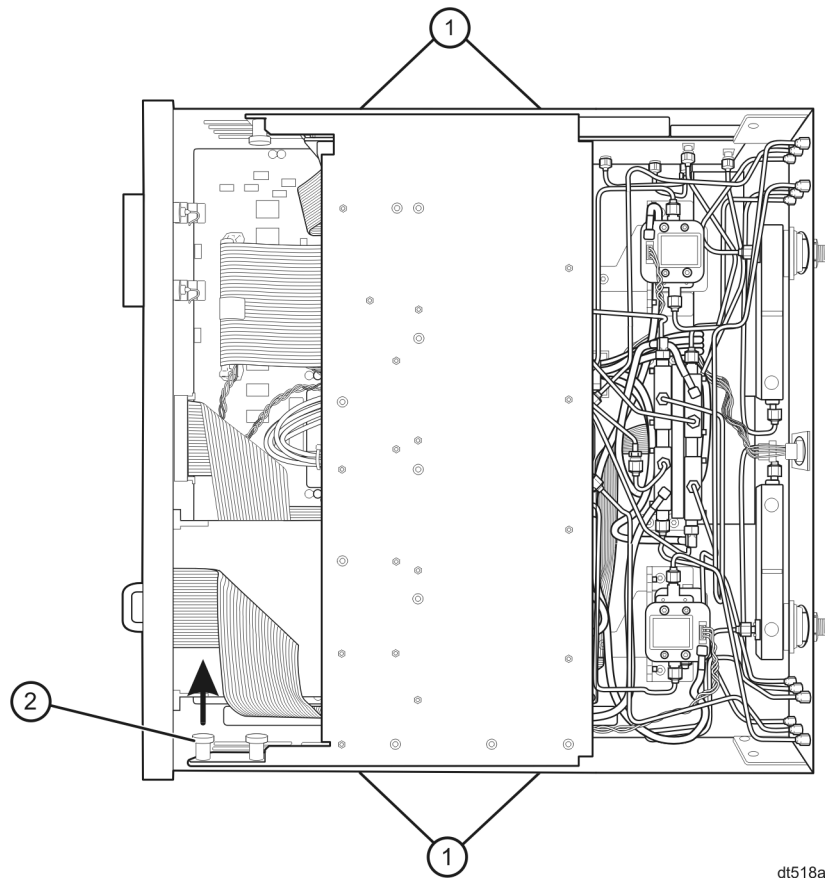

dt518a

Step 12. Connect the A12 Source 20 to A21 SOMA 50 Cable at the A12 Source 20

1. Place the analyzer top-side up on a flat surface.
2. Using a 5/16-inch wrench set to 10 in-lbs, connect the A12 source 20 to A21 SOMA 50 cable, W1, at the A12 source 20 as shown.

Figure 18 A12 Source Cable Connection

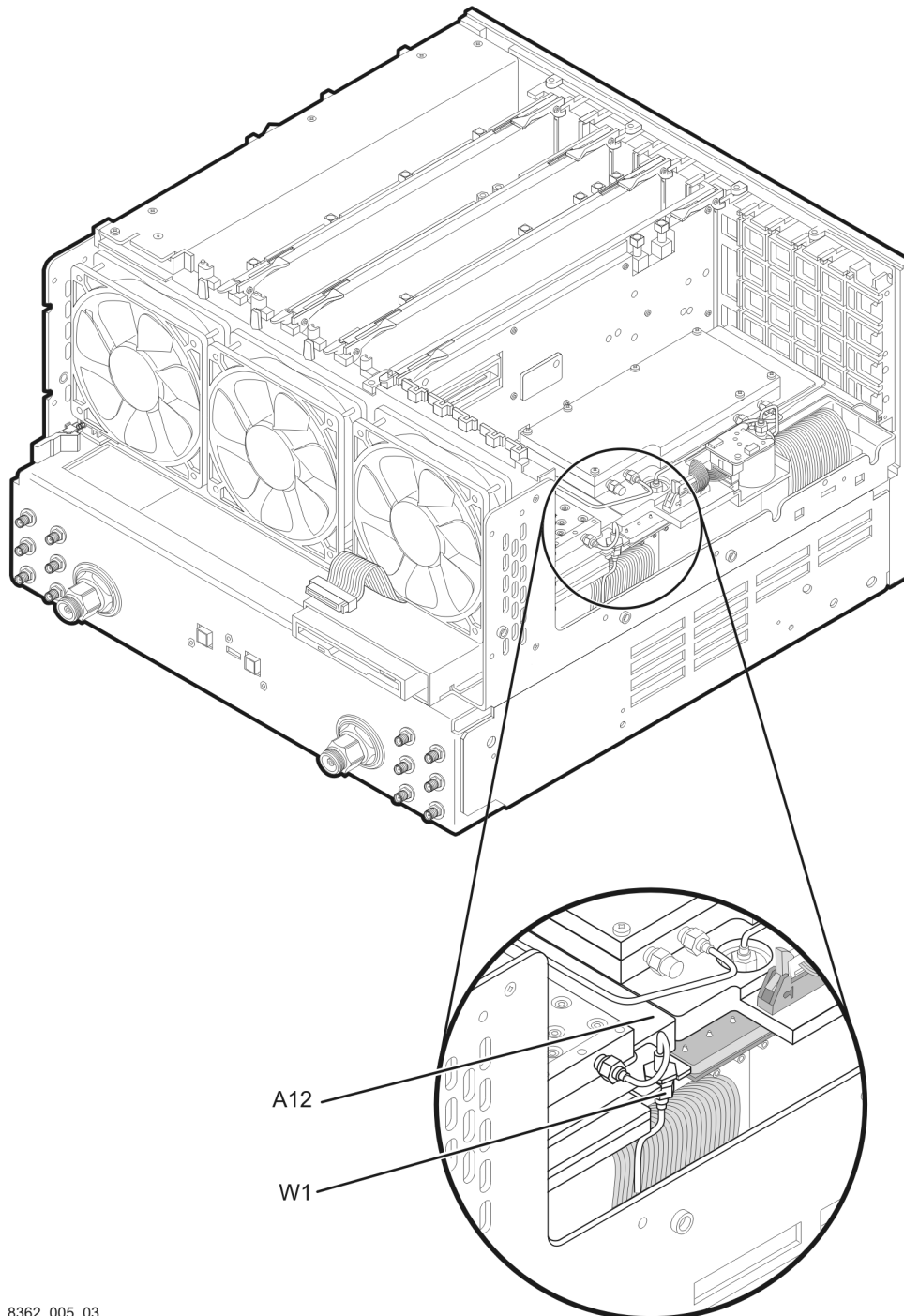

8362_005_03

Step 13. Replace the Front Panel Nameplate

Remove the Old Nameplate

1. Using a sharp object such as a knife blade, lift one end of the old nameplate (item ①). Be careful not to scratch the painted surface.
2. Using your fingers, pull the nameplate completely off of the front panel and discard it.
3. If any adhesive remains on the front panel surface, it can be removed by rubbing it with your finger. Do not use a sharp object to remove this adhesive. If necessary, the surface can be cleaned with isopropyl alcohol.

Install the New Nameplate

IMPORTANT If the Option 050 upgrade kit will be installed to extend the frequency to 50 GHz, do not install the new nameplate provided in this upgrade kit. Instead, use the one provided in the Option 050 upgrade kit.

1. Remove the protective backing from the new nameplate to expose the adhesive. Avoid touching the adhesive with your fingers as this may affect its ability to adhere to the front panel surface.
2. *Loosely* align the new nameplate over the recess in the front panel and apply lightly.
3. Once the nameplate is properly aligned, press it firmly onto the surface to secure it.

Figure 19 Model Number Nameplate Replacement

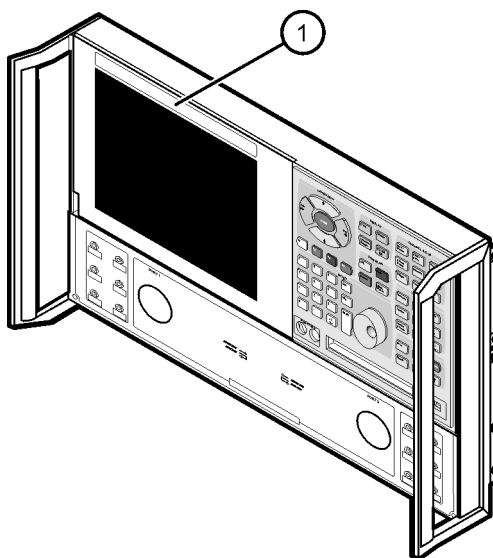

8364_023_16

Step 14. Reinstall the Front Panel Assembly and Front Panel Jumpers

Before Installing the Front Panel Assembly

1. Install a lock washer and hex nut on each of the 12 front-panel feed-through connectors. Using a 5/16-inch torque wrench, tighten these hex nuts to 21 in-lbs.
2. Lift and support the front of the analyzer chassis.

Install the Front Panel Assembly and Jumpers

1. Reconnect the ribbon cable (item ③) to the A3 front panel interface board.
2. Slide the front panel over the test port connectors being careful to align the power switch and floppy disk drive to their corresponding front panel cutouts. Ensure that the ribbon cable (item ③) is located below the fan to prevent it from being damaged by the fan blades.
3. Using a T-10 TORX driver, install the eight screws (item ②) in the sides of the frame.
4. Install the six semirigid jumpers, W60, (item ①) on the front panel, and, using a 5/16-inch torque wrench, tighten the connector nuts to 10-in lbs.

Figure 20 Front Panel Assembly Reinstallation

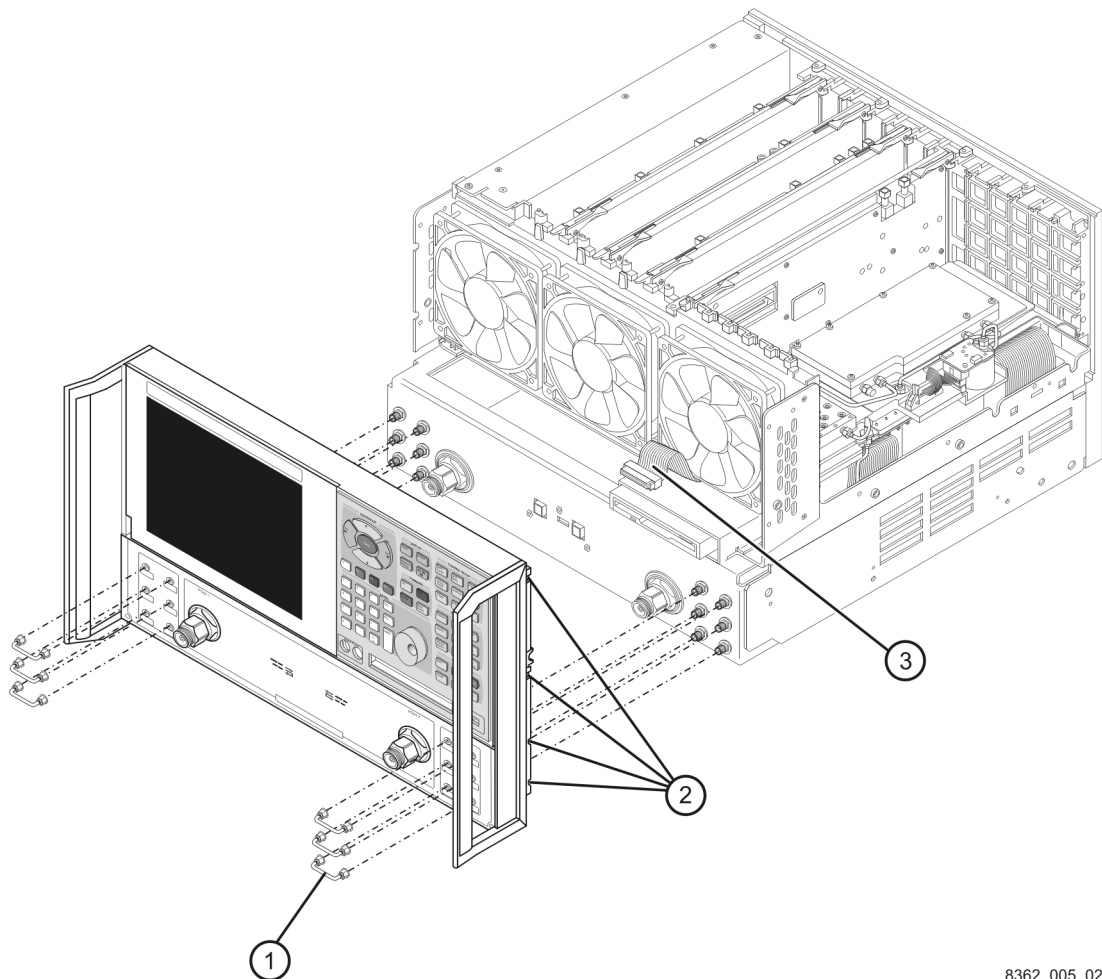

8362_005_02

Step 15. Reinstall the Inner and Outer Covers

Reinstall the Inner Cover

1. Place the inner cover on the analyzer as shown. There are two alignment pins on the front frame that align with holes in the front of the cover to ensure proper alignment.
2. Using a T-10 TORX driver, reinstall the eleven screws (item ①).

Figure 21 Inner Cover Reinstallation

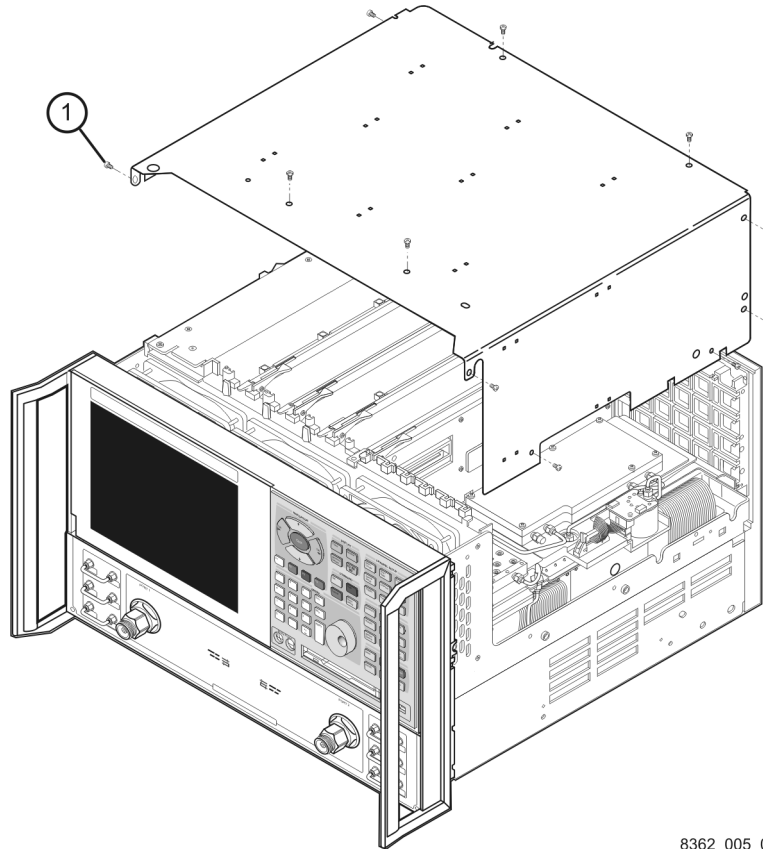

8362_005_01

Reinstall the Outer Cover

CAUTION This procedure is best performed with the analyzer resting on its front handles in the vertical position. *Do not place the analyzer on its front panel without the handles.* This will damage the front panel assemblies.

1. Slide the cover onto the frame.
2. Using a T-20 TORX driver, install the four rear panel feet (item ①) by installing the center screws (item ②).
3. Slide the four bottom feet (item ③) onto the cover.
4. Using a T-20 TORX driver, install the strap handles (item ④) by tightening the screws (item ⑤) on both ends.

Figure 22 Outer Cover Reinstallation

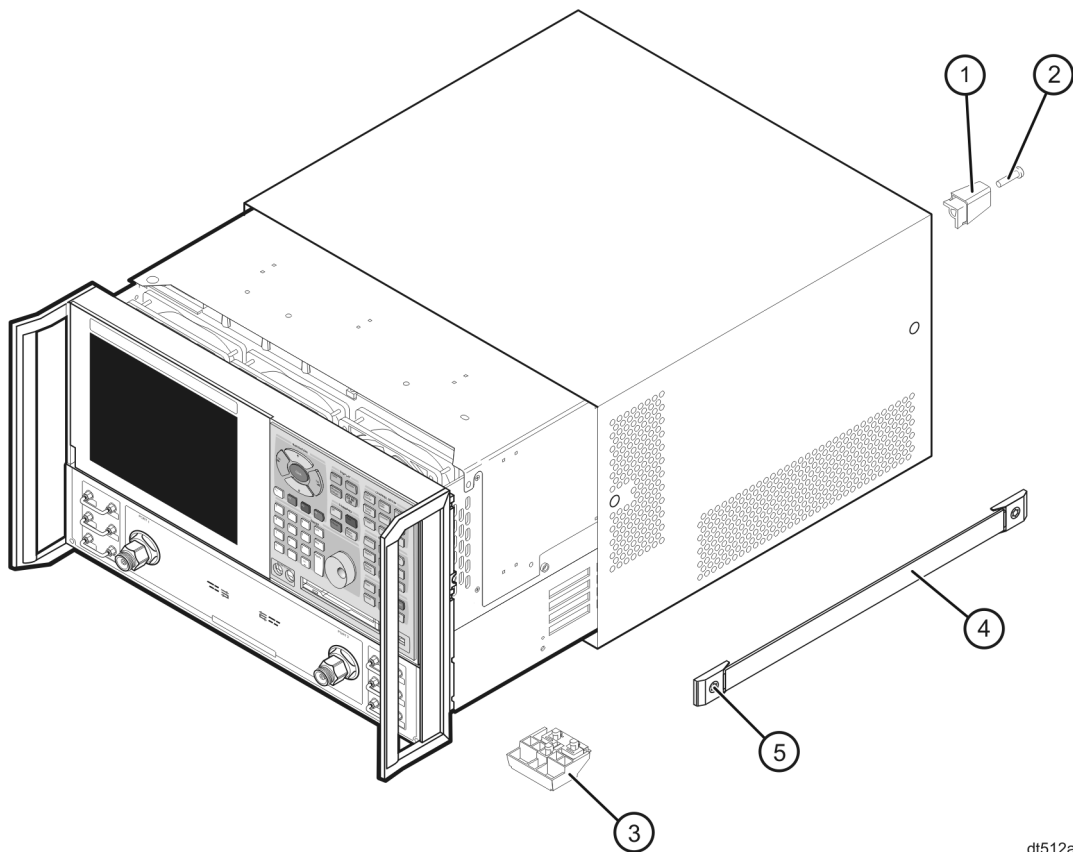

dt512a

Step 16. Enter the New Model Number

Procedure Requirements

- The analyzer must be powered up and operating.
- The Network Analyzer program must be running.
- A keyboard and a mouse are required for this procedure.

Enter the New Model Number

1. On the analyzer's **System** menu, point to **Service**, then click **Option Enable**.
2. Click **Repair**.
3. Check **Model shown is incorrect!**, then click **Begin Repair**.
4. In the **Model Change** box, select the new model number, **E8363A**.
5. Using the keyboard, enter the keyword in the box provided. The keyword is printed on the License Key Certificate. Enter this keyword *exactly* as it is printed on the certificate.
6. Click **Enter Model**.
7. Verify that the new model number displayed is correct, then click **YES**. If it is not correct, click **NO** and repeat the repair.
8. When the installation is complete, click **Exit**.

Verify the New Model Number

1. On the analyzer's **Help** menu, click **About Network Analyzer**.
2. Verify that the new model number, E8363A, is shown correctly in the display. Click **OK**.
3. On the analyzer front panel, press **Preset**. Verify that the full frequency range of the analyzer is correct. The analyzer should preset to a frequency range of 10 MHz to 40 GHz.

Step 17. Perform Source and Receiver Calibration Adjustments

The following adjustments must be made due to the change in the full frequency range of the analyzer.

- source calibration
- phase lock IF gain
- receiver calibration

These adjustments are described in the PNA service guide and in the PNA on-line HELP. A list of equipment required to perform these adjustments can be found at [“Equipment Required for Post-Installation Adjustments”](#) on page 9.

Performance Tests and System Verification

The analyzer should now operate and phase lock over its entire frequency range.

If you experience difficulty with the basic functioning of the analyzer, contact Agilent. Refer to [“Getting Assistance from Agilent”](#) on page 3.

Although the analyzer functions, its performance relative to its specifications has not been verified for the additional frequency range enabled by this upgrade.

It is recommended that a full instrument calibration be performed using the N2721A performance test software.

If the testing of the analyzer’s full range of specifications is not required, a system verification can be performed.

Refer to the analyzer’s service guide for information on performance tests and system verification.